



NIRAB CO.

**Air Valve
single chamber
double orifice**



Air valve, single chamber double orifice.

Flange: drilling according to DIN EN 1092-2 (DIN 2501)

Size: DN 50 - 200 mm

Pressure rating: PN10 - 25 bars

Features:

Automatic air venting of the fluid in the main and supply lines. In these types of valves the fluid flow activates the venting operation.

Large venting orifice allows large volumes of air to be released on start-up and enter the pipe for vacuum breaking on shut- down.

Small venting orifice allows volumes of air to be released under the fluid pressure.

Corrosion protection:

All casting parts, internal and outside, are covered with electrostatic epoxy powder coating.

Application:

For working pressure of 0.3 bar minimum and fluid temperature up 50°C (for other conditions on request).

Ranging:

DN (mm)	PN (bar)	Permissible Working Pressure (bar)	Permissible Working Temperature	Test pressure according to ISO 5208 in bar
				Hydrostatic test body and seat
200	10	10	70°C	15
50 - 200	16	16	70°C	24
50 - 200	25	25	70°C	37.5

Advantages:

- Reliable design.
- Small dimension.
- Sealing: EPDM or NBR.
- Screws of corrosion resistant steel A2.
- Electrostatic epoxy powder coating.
- Internal parts made of corrosion resistant steel.
- Higher capacity than double chamber valves.

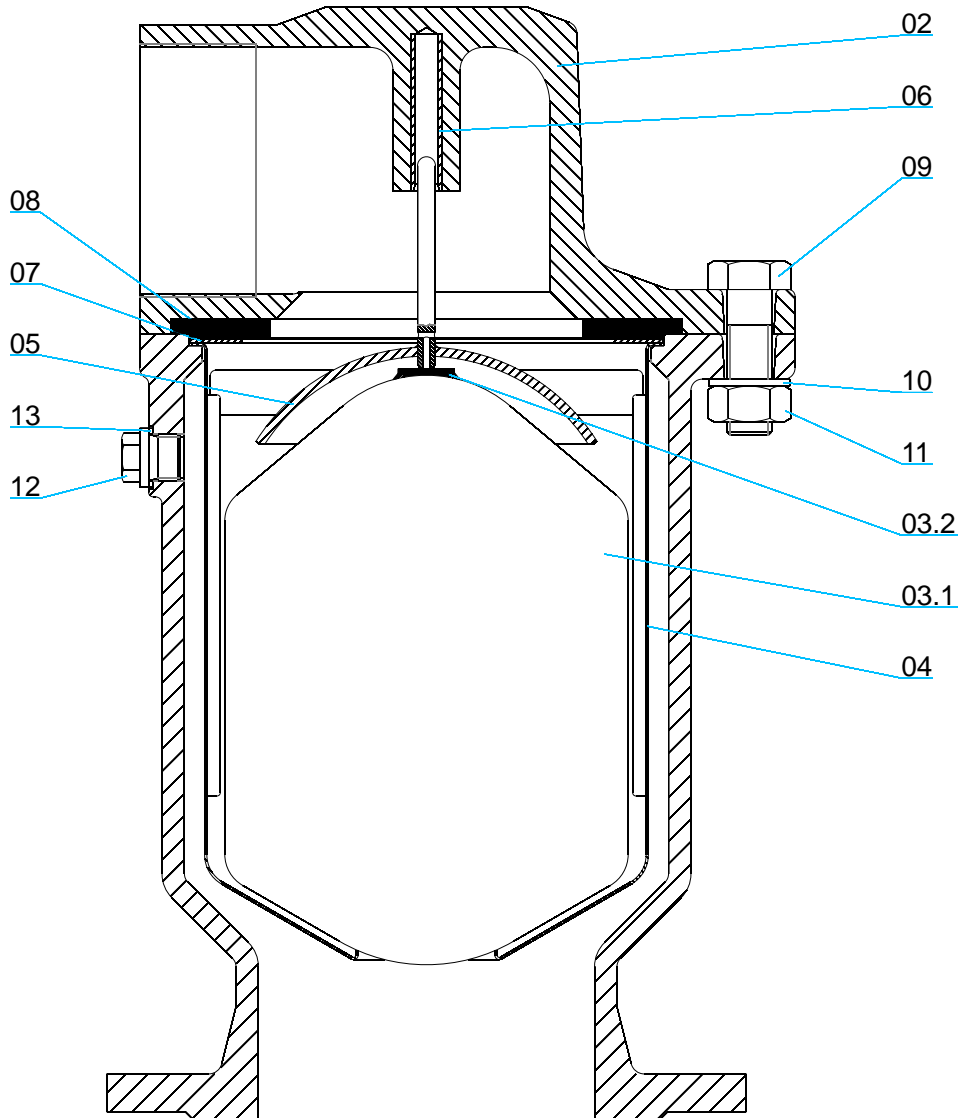

Parts list:

Part	Description	Material	Spare parts
1	body	EN-GJS-400-15 (1)	
2	cover	EN-GJS-400-15 (1)	
3.1	Float	1.4301	●
3.2	Gasket	EPDM / NBR	●
4	Shell body	1.4301	
5	Hood	1.4301	●
6	Bush	Al.Bz.	●
7	Disc	1.4301	●
8	Sealing ring	EPDM / NBR	●
9	Hexagonal Head Screw	A2 / Galvanized Steel	
10	Washer	A2 / Galvanized Steel	
11	Nut	A2 / Galvanized Steel	
12	Plug screw	S.Steel	
13	Gasket	CU	

(1) EN-GJS-500-7 can be product as requested.

Dimensions and weight:

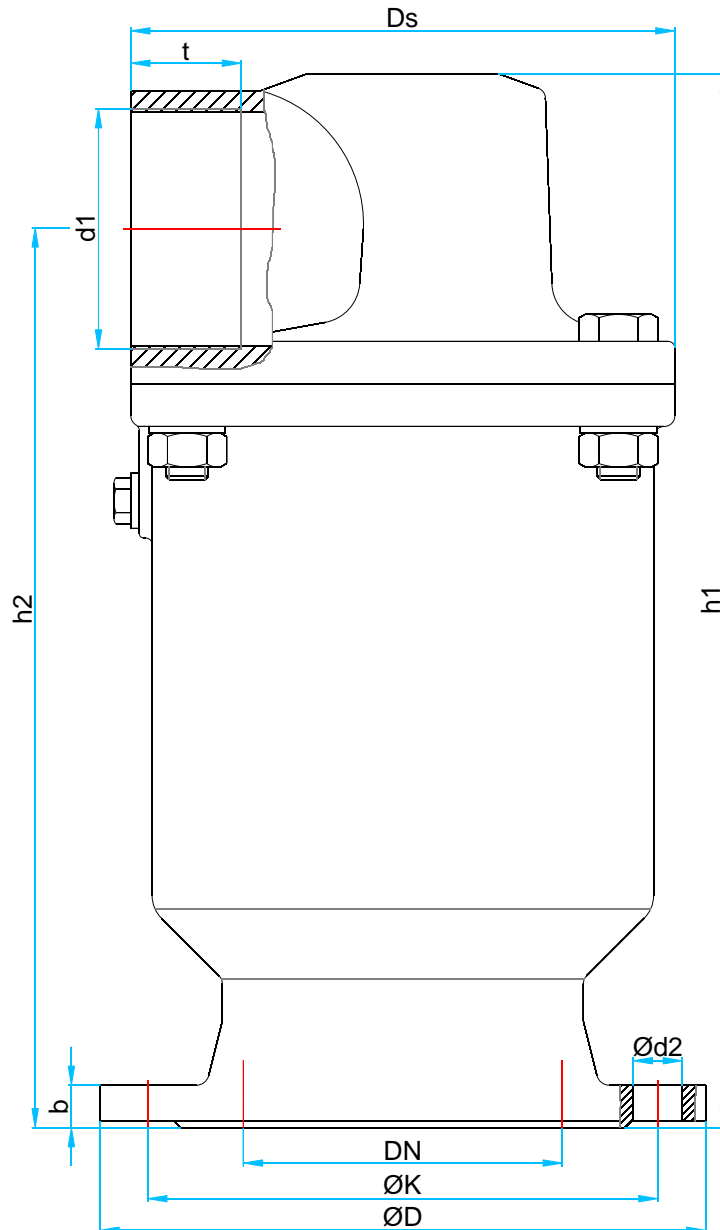

• DIN EN 1092-2 (DIN 2501)

DN mm	PN bar	•OD mm	•OK mm	•Od2 mm	•n	•b mm	h1 mm	h2 mm	Ds mm	d1 mm	t mm	~W (Kg)	~V (dm ³)
50	10.16.25	165	125	19	4	19	280	240	156	R1 ¼"	20	15	10
80	10.16.25	200	160	19	8	19	340	285	188	R2"	25	25	15
100	10.16	220	180	19	8	19	384	319	205	R2 ½"	30	28	20
	25	230	190	23								34	
150	10.16	285	240	23	8	20	510	423	266	R4"	52	56	40
	25	300	250	26								60	
200	10.16	340	295	23	PN10=8 PN16=12 PN25=12	21	510	423	266	R4"	52	75	40
	25	360	310	26								80	

Rate of inlet and outlet air chart

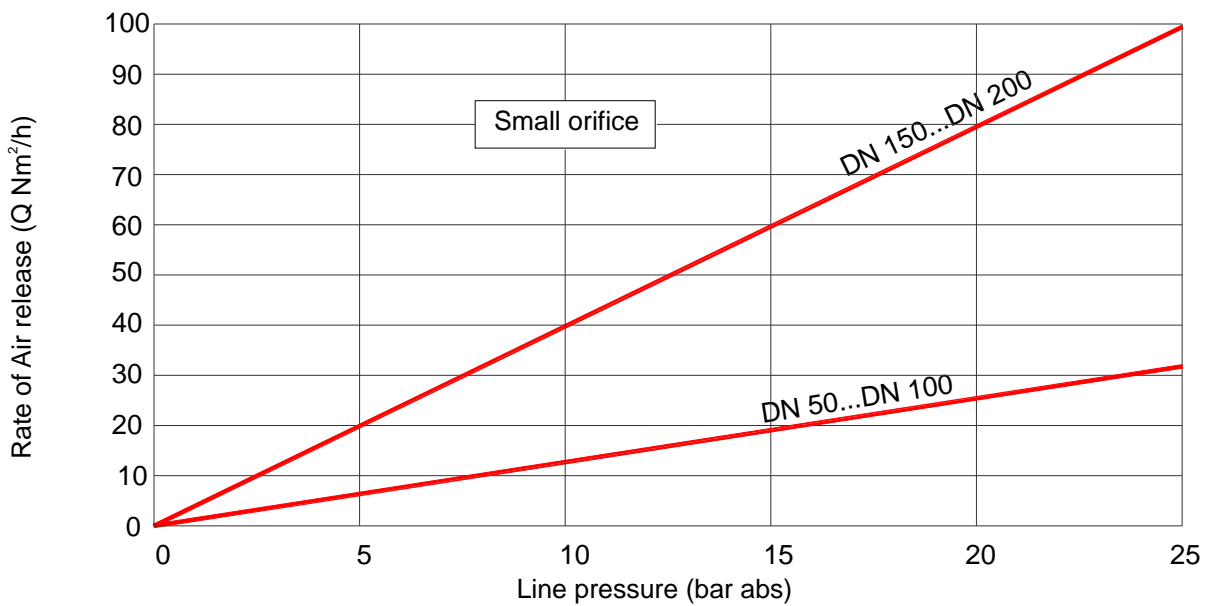
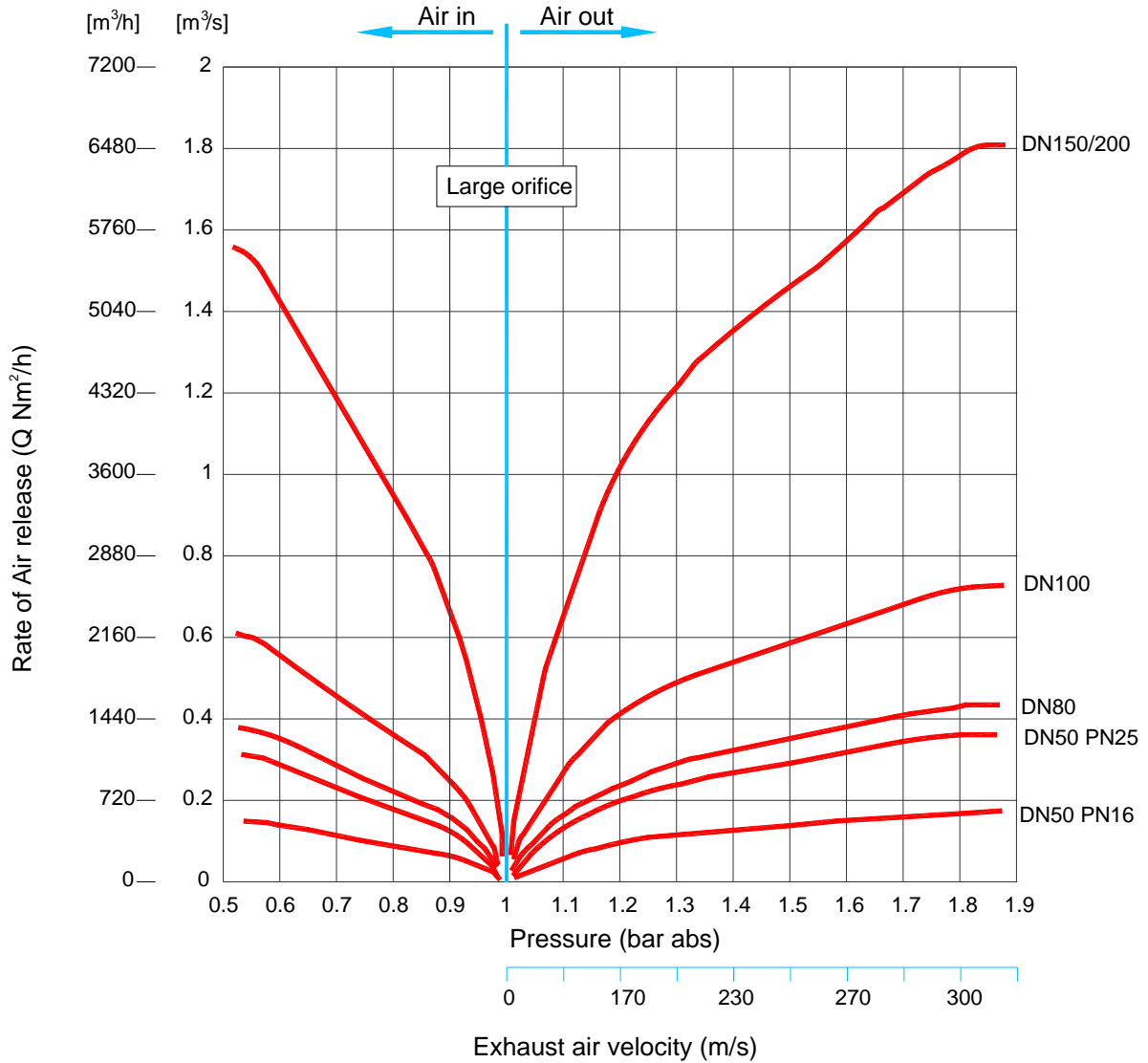

Operation:

Air venting in shut-down

Fig-1

When the pipe pressure drops to below atmosphere in the pipe drainage, the hood drops by its weight and opens the air orifice.

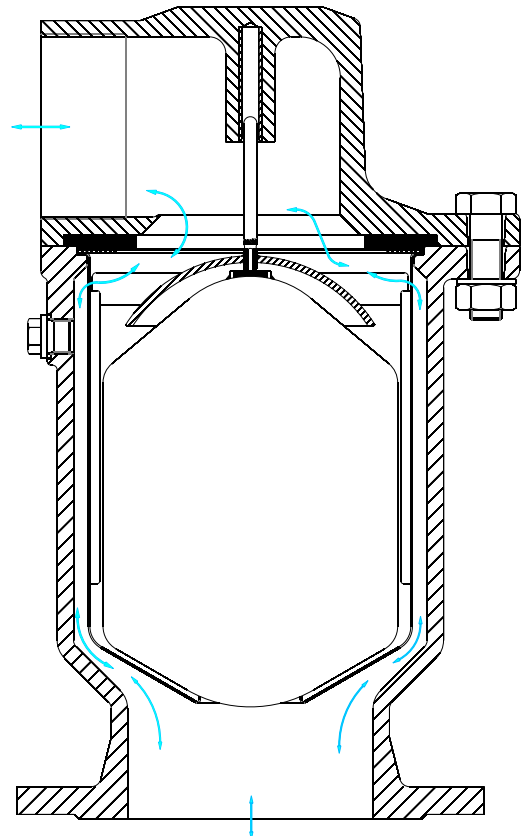

Fig-1

Air release in start-up

Fig-2

When the pipe line is filling up, the hood (for its geometrical shape) stays down until the air is completely released from the pipe. The air exhaust speed could reach up to the speed of sound.

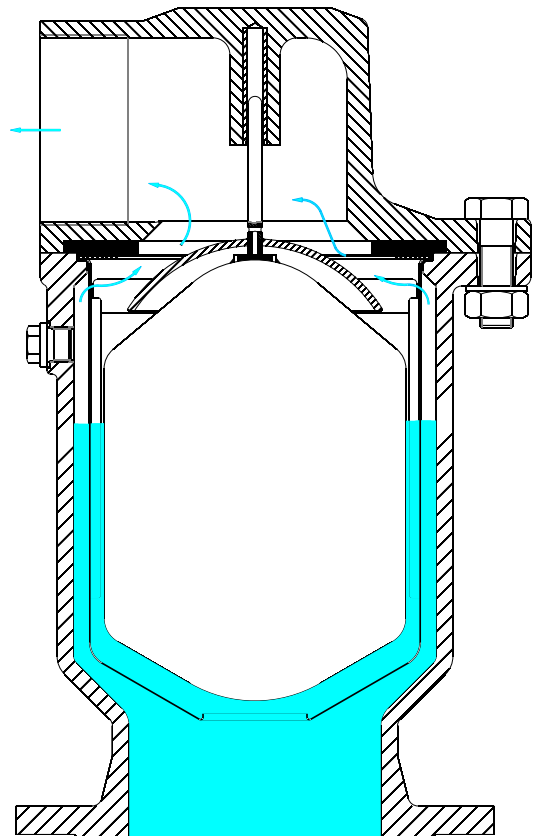

Fig-2

Fig 2-3

When the pipe is filled up, water level rises in the air valve forcing the float and the hood to rise and close the orifice.

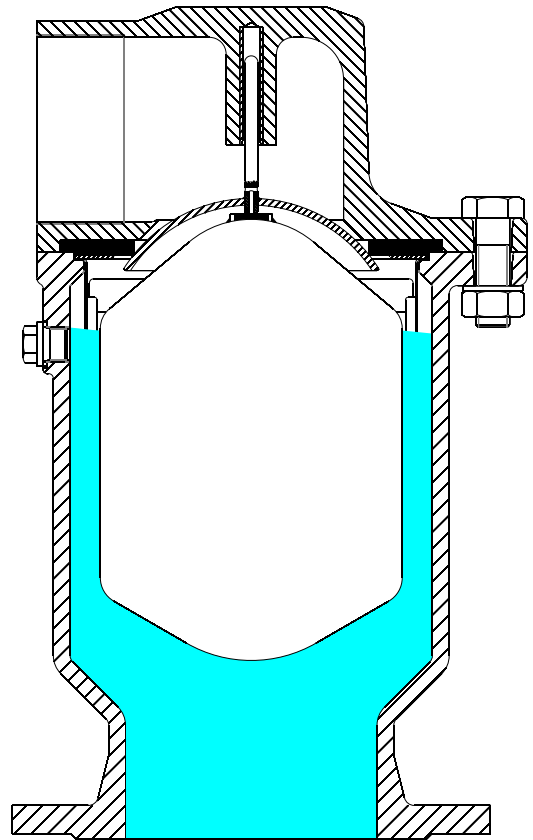

Fig-3

Air release during the line operation and under working pressure:

Fig-4

In pumping condition, air traps start to accumulate at high points in the pipe line, forcing the water level down, so that the float and the hood of the air valve stay down to allow the air out of the pipe line. The float closes the orifice when the air is completely released from the line, and stays closed under the line pressure.

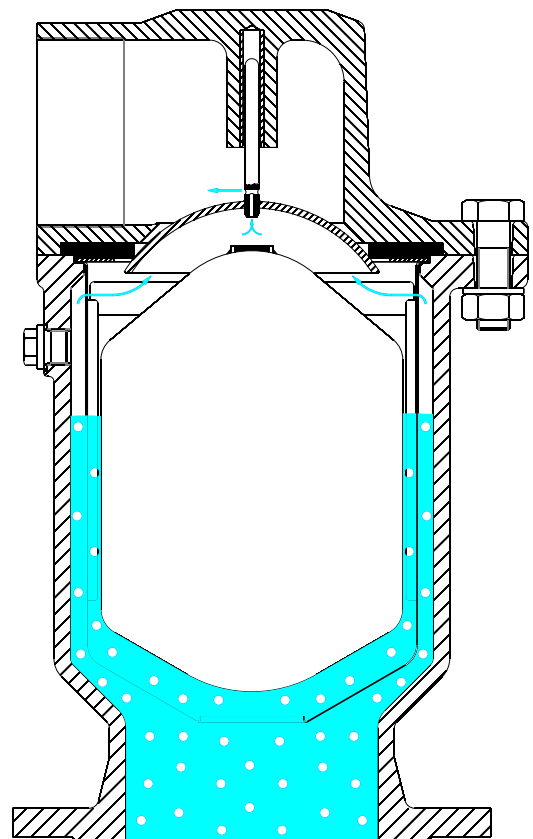

Fig-4



MIRAB CO.

28th (Ashery) St.
10 Km Special Karaj Road
Tehran-Iran
P.Code:13897 15851
P.O.Box:13445-487

Tel: +9821 -44545650 (7 Lines)
Fax: +9821 -44545658
mirab@mirab.net
www.mirab.net